

Customer

The company "Locus" is a leader in the antenna and terrestrial TV equipment market.

Task

To develop a digital set-top box for the receipt and decoding of terrestrial digital broadcasting signals in the DVB-T format and for the following reproduction of the decoded flow to the TV receiver. The digital set-top box is aimed at the lower price brackets and shall be performed at the minimal form factor. The software shall be implemented on the basis of Linux OS.

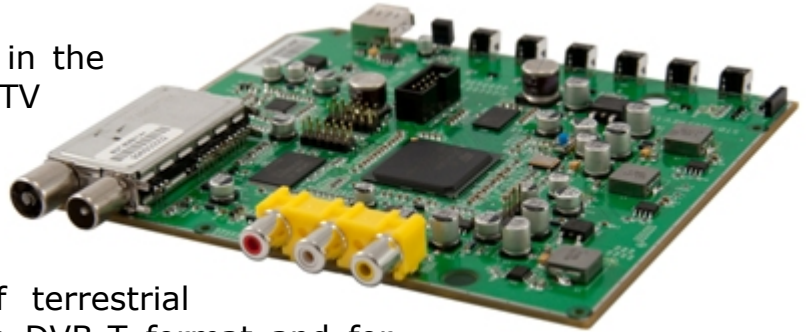

Solution

Main development tasks:

- The search and analysis of the offers made by the potential suppliers of the chips for the Set-top box solutions. The choice of the provider of the optimal solution for the project.
- The choice and optimization in accordance with the element base cost.
- The device estimate when in mass production.
- Elementary diagram development.
- The elaboration of design philosophy and circuit board tracing.
- The production and debug of the prototypes.
- The development and usability testing of the graphic user interface.
- Software development and testing.
- Certification tests for the electromagnetic compatibility and safety standards.

At an initial stage of the project implementation the search of the microprocessor producers has been performed. The brands that somehow revealed themselves in the Russian market, i.e. STMicroelectronics, NXP, Fujitsu and NEC, have been chosen. The choice of the producer has been made according to the following criteria: the cost of solutions, Linux support, technical support of the design.

The analysis of the Set-top box chips producers and consideration of the existing designs on their element base resulted in the decision to use the chips of STMicroelectronics company. In addition to the processors this company produces a number of supplementary chips and active components for the STB, covering



practically all the nomenclature of the digital set-top boxes components required. It considerably reduces the device prime cost at a whole. Besides STMicroelectronics implements maintenance and full technical support at the device development stage, and also provides debugged solutions for the use of the software based on the Linux OS.

Main requirements to the designed platform

The digital set-top box shall receive the signals in the range of the operating rates of 174–863 MHz, decode video flows of the MPEG-2/4 format and transmit the decoded video to the TV receiver. The output video signal format is SD (720x576), composite; the modulation is PAL.

The digital set-top box is connected to the TV receiver via the RCA connector (composite video output). It shall also contain a key control panel and an infrared sensor for receiving commands from the remote control. The software update shall be performed from the external USB-memory.

The device shall perform the following functions:

- Program schedule viewing (EPG),
- Planner (switching on of the selected program),
- Editing the channels,
- "Favorite" channels,
- Photo viewing and music content playing from the external USB-memory.
- Multilingual user support.

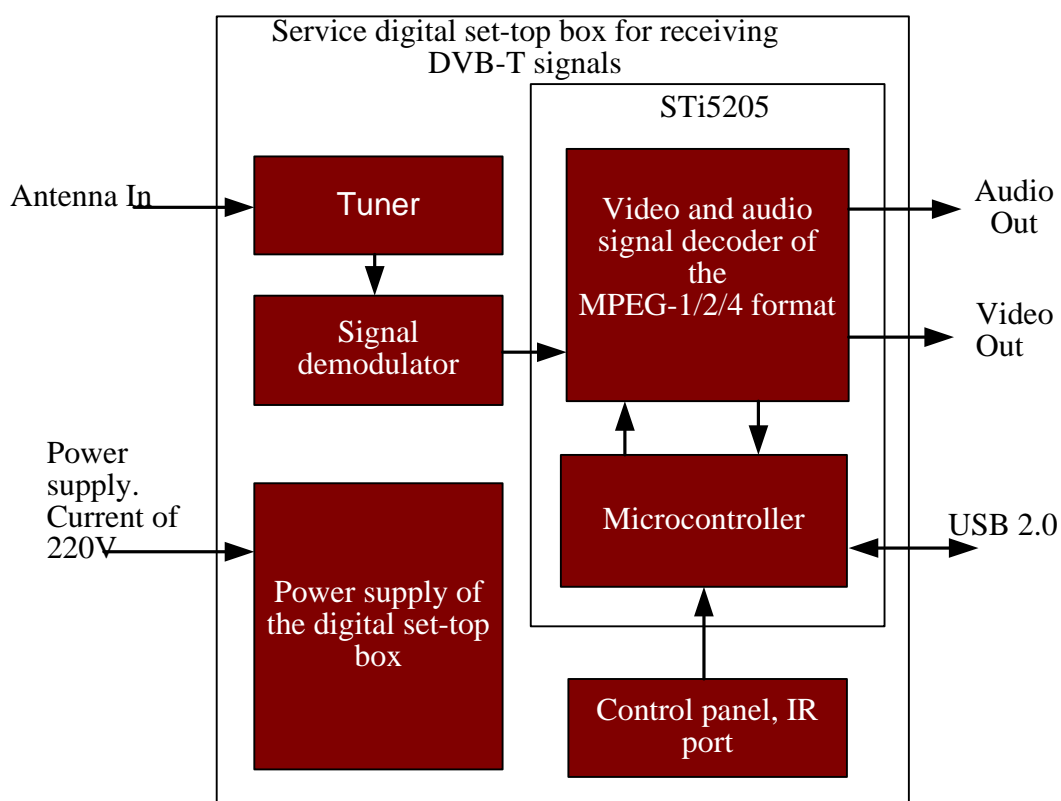

Figure 1. General structure of the device

The digital set-top box shall be performed at the minimal form factor. The software on the basis of the Linux OS shall provide for the option of quick device setting/parameter modification depending on the user's needs.

Circuit design

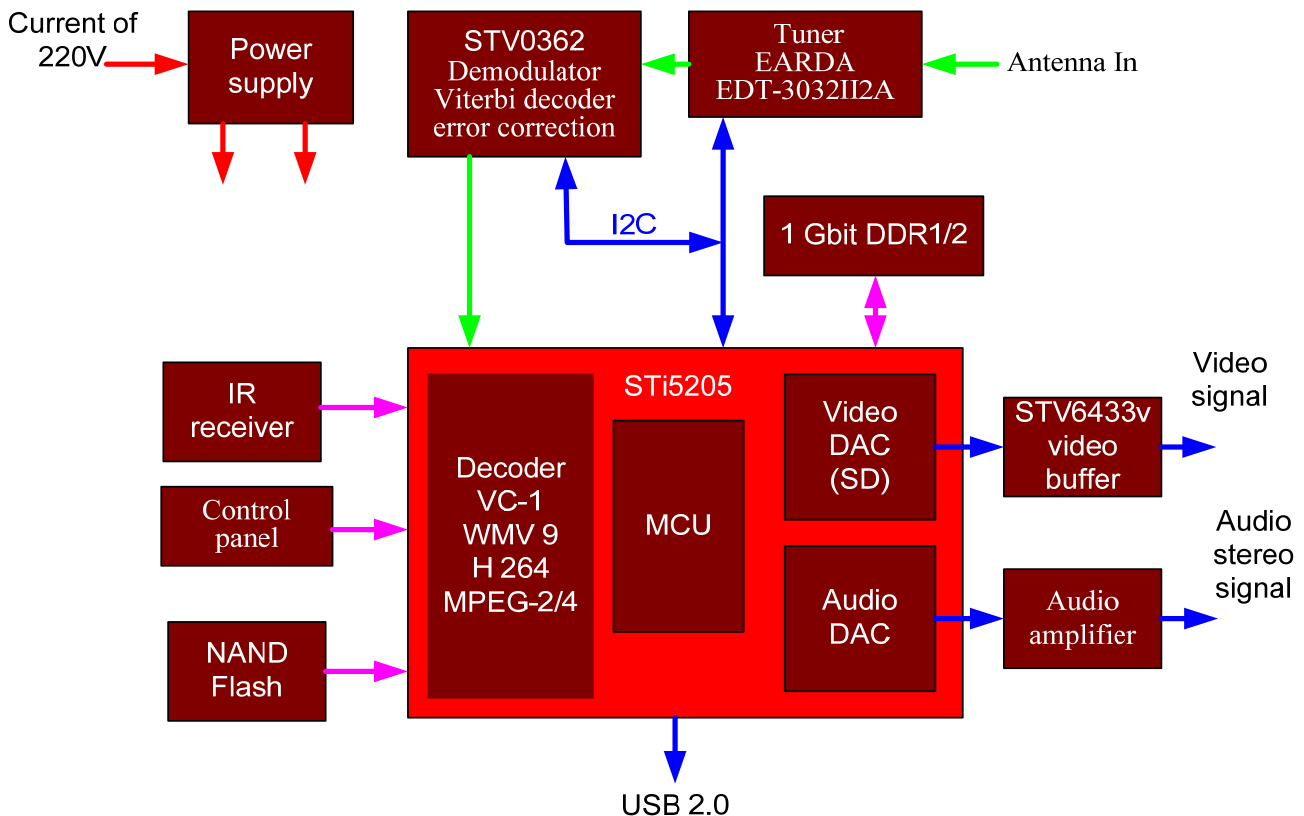

Figure 2. Layout of the structure of the device

STi5205 by STMicroelectronics has been chosen as the microprocessor for the project. STi5205 contains audio and video decoding hardware facilities (MPEG-2 ISO/IEC 13818 /MPEG-4 AVC H.264), and also ST40 core compatible with Linux, Windows CE and OS21 that is responsible for the implementation of the device user functions. The audio and video digital-analog converter (DAC) is implemented on the microprocessor chip. The external STV6433 chip is used for the video signal filtering and amplification, and external operational amplifiers are used for the audio data.

The device is operated using the keyboard, implemented on the same circuit board or distantly via the IR port.

STV0362 chip by STMicroelectronics is used as the demodulator. The tasks of the above also include the restoration of errors and tuner amplification operation.



When choosing the tuner for the project a number of suppliers has been considered: Philips, Earda, Selteka, Sharp. The choice of the producer has been made according to the following criteria: the cost of the solutions, the support of drivers in Linux, signal receipt engineering data. Consequently Earda company has been chosen as the tuner supplier, EDT-3032 module has been used. The tuner is compact and has one supply voltage.

One DDR2 plank of 128 MB is used as the program and data memory. OS boot of the digital set-top box is performed from the external NAND Flash. The USB 2.0 connector is mounted onto the back panel for connecting the external reading device.

The digital set-top box can be used together with the active antenna, the power supply of which is 5V 75mA. In addition to the high-frequency input (for receiving DVB-T signal) the high-frequency output for the serial connection of the digital set-top boxes is implemented in the device.

For the cost reduction of the designed product the four-layer circuit board is implemented with the one-side mounting and is performed at the minimal form factor. The tracing of DDR2 and differential pairs is performed taking into account signals integrity with the calculation of the impedances required.

The digital set-top box has passed certification tests for the safety and electromagnetic compatibility standards.

Software

The digital set-top box software has been developed on the basis of the Linux OS and STAPI — low-level program interface, supplied by STMicroelectronics. For implementing the graphic user interface the graphical library Qt, adapted for the processors of the Sti71xx/STi52xx family, has been used.

Main modules of the software:

- tuner operation module (band scanning, switching between the channels, flow receipt);
- flow player MPEG-2/4;
- graphic interface (channel, scanning choice, operating the «favorite» channels);
- remote control support module;
- service utilities (software renovation and etc.).

All the main requirements to the functional of the device being developed have been met. Besides, Promwad company has developed and integrated a convenient multifunctional user interface. Device operation is simplified to the maximum: everyone who knows how to use the TV remote control, will easily become familiar with the device operation principles.

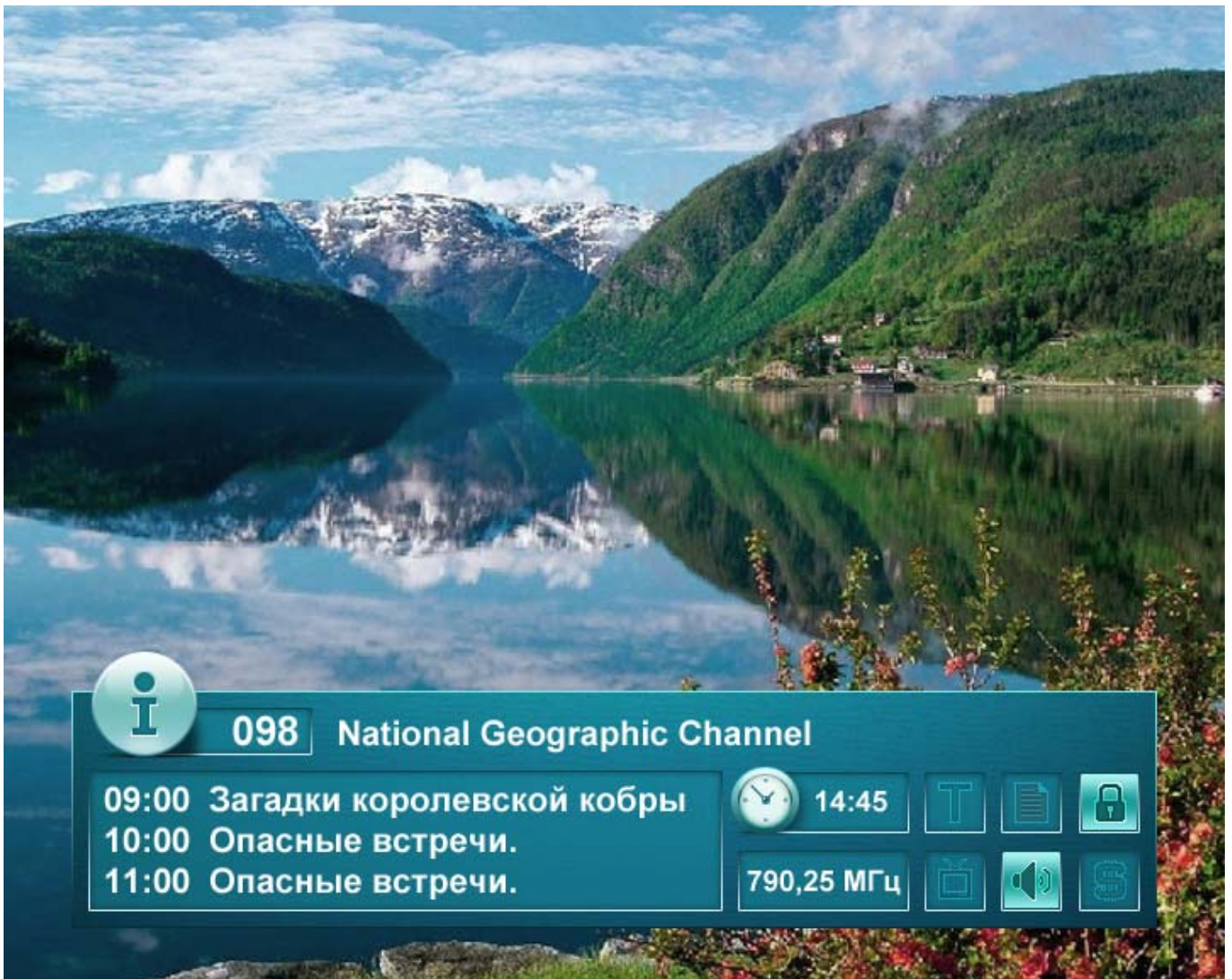

Advantages

- The use of chips of one producer makes the technical support more effective.
- A minimum of components in the basic configuration.
- Low prime cost of the product.

Technologies	Linux, DVB-T, Qt
Programming language	C, C++
Engineering environment	STWorkbench, GCC, QtCreator
Project management means	SVN, Dotproject, Mantis
Man-day	180 man-days
Project due date	6 months